



BATTERY PERFORMANCE SPECIFICATIONS





The PowerSafe® DSG battery has been carefully engineered to meet the varying power needs of the utility market. The lead-calcium design reduces the maintenance (watering intervals) associated with lead-antimony batteries. This makes the DSG battery ideal for challenging utility switchgear applications.

Its 0.25 inch positive grids are one of the thickest in the industry, making it an excellent long discharge battery and ideally suited for the complex duty cycle requirements of the switchgear application. The multi-cell construction helps to minimize floor space. The DSG was designed with individual posts for each cell to help ease and simplify the integration of battery monitoring and test equipment used in routine maintenance inspections.

The PowerSafe DSG battery also features EnerSys' time tested Slide-Lock™ post seal design. Multi-cell construction requires fewer units, resulting in lower installation costs. All battery systems are rated at 100% capacity at initial discharge and offer 20 year life expectancy in float service at 77° F (25° C) ambient temperature. The individual cell post feature along with the Slide-Lock post seal and 100% initial capacity make the DSG battery a smart choice for utility switchgear applications.

Features

- Slide-Lock™ Post seal design
- Calcium grids — lowest waterloss, lowest maintenance
- Individual posts to monitor individual cell performance in a multi-cell container
- Thick grids provide excellent long discharge rate performance and long life
- 100% Initial capacity.
- Applications: Switchgear, Utility, Telecommunications
- 20 year life expectancy in float service at 77°F (25°C) ambient temperature
- Capacity from 295 Ah to 745 Ah

Specifications

- Plate thickness:
Positive: 0.25 in/6.4 mm
Negative: 0.17 in/4.3 mm
- Plate suspension type:
Positive: Bridge Hung
Negative: Bottom supported
- Sediment space: 1.04 in/26.4 mm
- Electrolyte over plates: 2.88 in/73.1 mm
- Specific gravity: 1.215 standard
- Container: Styrene Acrylonitrile Copolymer, optional PC
- Cover: Made from flame retardant PVC
- Separators: Microporous rubber
- Bolt connectors: Stainless steel, Standard English measure, Hex-Head
- Intercell connectors: Tin plated copper, optional lead plated copper
- Retainers: "Vitrex" — glass fiber
- Float voltage settings: Acceptable min/max: 2.17/2.26 Vpc, Recommended: 2.21 Vpc
- Posts: Lead plated copper
DSG-05 thru DSG-13 — one positive post and one negative post per cell
- Vent type: Flame Arrestor, Fused Alumina
- Post seal type: Slide-Lock™

General Specifications

PowerSafe® DSG Battery TYPE*	NOM. Ah CAP ¹	Nominal Dimensions						Weights - Volumes							
		Length**		Width		Height		Unpacked		Domestic Packed		Electrolyte Only / 1.215 S.G.			
		in	mm	in	mm	in	mm	lbs	kg	lbs	kg	lbs	kg	gal	l
4DSG-05	295	9.5	241	16.0	406	22.0	558	267	121.1	276	125.2	64	29.0	6.3	24
4DSG-07	375	9.5	241	16.0	406	22.0	558	328	148.8	337	152.9	59	26.8	5.8	22
4DSG-09	595	16.7	424	16.0	406	22.7	576	494	224.1	509	230.9	134	60.6	13.2	50
4DSG-11	680	16.7	424	16.0	406	22.7	576	555	251.7	570	258.5	123	55.8	12.2	46
4DSG-13	745	16.7	424	16.0	406	22.7	576	617	279.9	632	286.7	113	51.3	11.1	42

* Prefix number indicates cells per unit. Suffix number indicates total plates per cell.

** 0.25" must be added between units for spacing purposes when calculating total battery length.

¹ Nominal Amp hour capacity at the 8 hour rate.

Constant Current

1.215 Specific Gravity

Discharge Rates in Amperes per Cell* to 1.75Vpc at 77°F (25°C)

PowerSafe® DSG Battery Type	NOM Ah CAP ¹	Minutes			Hours									
		1	15	30	1	1.5	2	3	4	5	8	12	24	72
4DSG-05	295	405	307	234	161	125	102	77	62	53	37	26.2	15.4	6.3
4DSG-07	375	578	451	337	227	174	141	104	83	69	47	33.0	18.2	6.9
4DSG-09	595	764	605	461	320	249	205	154	124	105	74	53.0	31.3	12.9
4DSG-11	680	946	748	566	387	298	245	183	146	123	85	60.2	34.6	13.7
4DSG-13	745	1119	887	666	449	343	279	206	164	137	93	65.2	35.9	13.4

1.215 Specific Gravity

Discharge Rates in Amperes per Cell* to 1.81Vpc at 77°F (25°C)

PowerSafe® DSG Battery Type	NOM Ah CAP ¹	Minutes			Hours									
		1	15	30	1	1.5	2	3	4	5	8	12	24	72
4DSG-05	295	274	256	203	147	117	98	75	61	52	37	26.2	15.4	6.3
4DSG-07	375	386	369	289	202	158	130	98	79	67	46	32.7	18.2	6.8
4DSG-09	595	527	496	395	287	229	192	148	121	104	74	53.0	31.3	12.9
4DSG-11	680	640	610	481	344	272	226	172	140	119	83	59.7	34.6	13.7
4DSG-13	745	746	720	562	396	309	255	192	154	130	89	63.3	35.3	13.3

* Ampere values listed represent 100% of the initial capacity.

** 1.215 S.G. electrolyte at 77°F (25°C) includes intercell connector drop.

¹ Nominal Amp hour capacity at the 8 hour rate.

All data subject to change without notice.

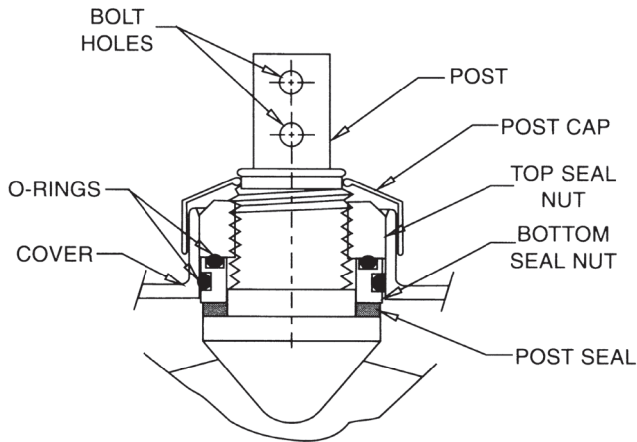

4DSG-09, 11, 13 Models Shown

* 4DSG-05, 07 models have a single hole terminal post.

Catalog Rint and Isc Catalog Values*

PowerSafe® DSG Battery Size	*Resistance milliohms	Isc Amps
4DSG-05	0.52	3850
4DSG-07	0.36	5560
4DSG-09	0.27	7410
4DSG-11	0.22	9090
4DSG-13	0.19	10640

* Resistance values are for reference only (not intended to represent an ohmic value or base line measurement)

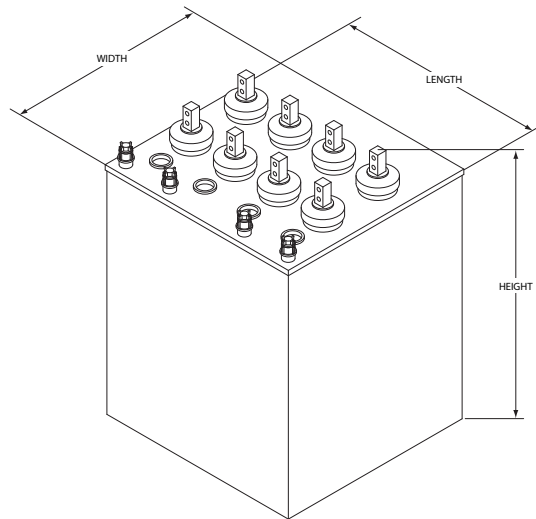

4DSG-09, 11, 13 Models Shown

* 4DSG-05, 07 models have a single hole terminal post.



www.enersys.com

EnerSys
P.O. Box 14145
Reading, PA 19612-4145
USA
Tel: +1-610-208-1991
+1-800-538-3627
Fax: +1-610-372-8613

EnerSys EMEA
Brussels, Belgium
Tel: +32 (0)2 247 94 47

EnerSys Asia
Guangdong, China
Tel: +86-755-2689 3639

Represented by:

Printed in the U.S.A.
© 2011 EnerSys. All rights reserved.
Trademarks and logos are the property of EnerSys and its affiliates except ISO, which is not the property of EnerSys.